



# THE FUTURE IS CAST

## LOW ROLLING RESISTANCE

High quality wheels, rollers and ball bearings



## ERGONOMIC HANDLE DESIGN

Loop design for comfort and safety

## NEW ONE-PIECE HYDRAULIC PUMP

New design improves performance and reliability



## PROTECTIVE HANDLE BUMPER

Protects pump piston from wall impact

## HIGH PERFORMANCE FRAME

Solid construction finished in durable powder coating



## ENTRY SLIDE AND EXIT ROLLERS

Fork tip design provides smooth pallet transition

# LIFFRITE®



**THE NEW TITAN SERIES  
HAND PALLET TRUCK FROM LIFT-RITE.**

An all new hydraulic pump design is the engine driving the Titan Series. The pump body is cast in one piece to keep oil in the pump and off your floor. A new lowering valve cartridge provides superior operator lowering control. A new high quality thrust load ball bearing and plate equipped with grease fittings makes load steering easier than ever before.

**2 YEAR PUMP WARRANTY**

Lift-Rite backs our new pump unit with a full 2 year exclusive warranty.

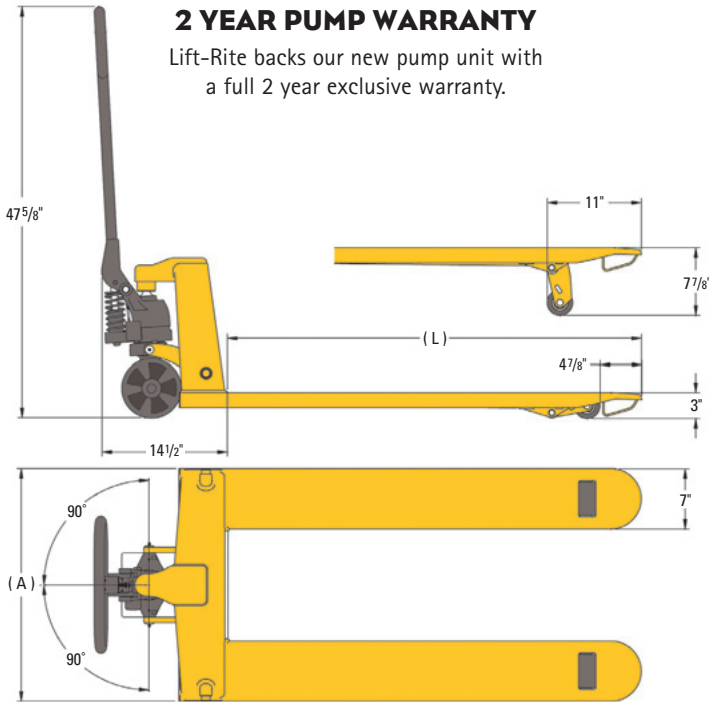

MODEL No.	CAPACITY (LBS.)	FRAME WIDTH (A) (IN.)	FORK LENGTH (L) (IN.)	FORK WIDTH (IN.)	WEIGHT (LBS.)
LCR55270036	5,500	27	36	7	147
LCR55270042	5,500	27	42	7	157
LCR55270048	5,500	27	48	7	167
LCR55205036	5,500	20.5	36	7	142
LCR55205042	5,500	20.5	42	7	147
LCR55205048	5,500	20.5	48	7	152

Due to LIFT-RITE'S continuing product development program, specifications are subject to change without notice. Contact your authorized LIFT-RITE dealer to confirm the most recent specifications.



Lift-Rite Inc., 55 Walker Drive, Brampton, Ontario, L6T 5K5  
Phone (905) 456-2603 • Fax (905) 456-1383 • Web [www.liftrite.com](http://www.liftrite.com)



ISO 9001:2000 REGISTERED  
Quality Management System



ISO 14001:2001 REGISTERED  
Environmental Management System